

Absolute encoders - analog

Encoder with cable-pull

Magnetic sensing, resolution 12 bit

BMMS M50 / M75 analog / cable-pull - MAGRES



BMMS M75 analog with connector M12

Features

- Encoder with cable-pull
- Magnetic sensing method
- Resolution: 12 bit
- Interface analog 0...10 V / 0.5...4.5 V / 4...20 mA
- Measuring length 5000 mm or 7500 mm
- Removable caps for water outlet
- Teach inputs
- Extremely flat design
- Extremely light thanks to housing of plastic and aluminum

Technical data - electrical ratings

Voltage supply	8...30 VDC
Reverse polarity protection	Yes
Short-circuit proof	Yes
Consumption typ.	35 mA (24 VDC, w/o load)
Initializing time	≤500 ms after power on
Response time	<1 ms
Interface analog	0...10 V / 0.5...4.5 V / 4...20 mA Resolution: 12 bit
Function	Linear position feedback
Sensing method	Magnetic
Linearity	0.2 % of whole measuring range
Repeatability typ.	3 mm
Interference immunity	DIN EN 61000-6-2
Emitted interference	DIN EN 61000-6-4
Programmable parameters	Measuring range teachable
Diagnostic functions	Self-diagnosis Reading back voltage output
Factory setting	Entire measuring range Min. output at 0 m Max. output at 5 m, 7.5 m

Technical data - mechanical design

Protection DIN EN 60529	IP 65 (encoder)
Materials	Encoder housing: aluminium Cable-pull housing: PA6 GF30 Cable: Stainless steel cable sheathed with polyamide
Operating temperature	-40...+85 °C
Service life	Type >500000 strokes
Cable diameter	0.45 mm
Relative humidity	95 % temporary condensing
Resistance	DIN EN 60068-2-6 Vibration 10 g, 10-2000 Hz DIN EN 60068-2-27 Shock 50 g, 11 ms
Weight approx.	900 g
Connection	Connector M12, 5-pin Connector M12, 8-pin Cable 2 m
Bending radius	Cable: >55 mm
Special characteristics	Coated electronic
Instruction	Please consider the assembly instructions

BMMS M50

Measuring length	5000 mm
Cable acceleration	≤25 m/s ²
Pull-in force	>5 N
Pull-out force	≤8 N

BMMS M75

Measuring length	7500 mm
Cable acceleration	≤15 m/s ²
Pull-in force	>7 N
Pull-out force	≤13 N

Absolute encoders - analog

Encoder with cable-pull

Magnetic sensing, resolution 12 bit

BMMS M50 / M75 analog / cable-pull - MAGRES

Part number

Measuring length max. 5 m

BMMS M505N24 12/16 00

				<u>Connection</u>
			5	Cable 2 m, radial
			M	2 x connector M12, 5-pin, radial (redundant version)
			N	Connector M12, 5-pin, radial (not redundant version)
			Q	Connector M12, 8-pin, radial
				<u>Resolution</u>
			12/16	12/16 bit single-/multiturn
				<u>Analog signals</u>
	U			0...10 VDC
	5			0.5...4.5 VDC
	V			4...20 mA
	7			0.5...4.5 VDC redundant
	Y			0...10 VDC redundant
	Z			4...20 mA redundant

Measuring length max. 7.5 m

BMMS M755N24 12/16 00

				<u>Connection</u>
			5	Cable 2 m, radial
			M	2 x connector M12, 5-pin, radial (redundant version)
			N	Connector M12, 5-pin, radial (not redundant version)
			Q	Connector M12, 8-pin, radial
				<u>Resolution</u>
			12/16	12/16 bit single-/multiturn
				<u>Analog signals</u>
	U			0...10 VDC
	5			0.5...4.5 VDC
	V			4...20 mA
	7			0.5...4.5 VDC redundant
	Y			0...10 VDC redundant
	Z			4...20 mA redundant

Accessories

Connectors and cables

10153968	Female connector M12, 5-pin, straight, without cable
11046266	Female connector M12, 5-pin, straight, 5 m cable
10156842	Cable with male/female M12, 5-pin, angled, A-coded, 5 m
11144306	Cable with male/female M12, 5-pin, straight, A-coded, 5 m
10146775	Female connector M12, 8-pin, straight, without cable

Absolute encoders - analog

Encoder with cable-pull

Magnetic sensing, resolution 12 bit

BMMS M50 / M75 analog / cable-pull - MAGRES

Terminal significance

+Vs	Cable-pull encoder supply voltage. (Redundant configuration provides decoupled dual voltage supply (+Vs1/+Vs2) separated by diodes.
0 V	Cable-pull encoder ground connection relating to +Vs.
Iout	Current output. Load: <500 Ω
Uout	Voltage output. Current output: max. 10 mA Load resistor: >1 kΩ between Uout / 0 V
Set	Teach input. Resting state: Low Level High: >0.7 x +Vs Level Low: <0.3 x +Vs Pull-Down resistor: 10 kΩ
DV/Status	Diagnostic output/Teach output. R _L - Vs: High: >(Vs -1.0 V) Low: <3.0 V R _L - GND: High: >(Vs -3.0 V) Low: <1.0 V I _{Lmax} = 10 mA Upon any short-time disturbance, DV will go on Low for 1 second.
Drain	Encoder housing.

Teach process

The teaching functionality will be disabled 5 minutes after cable-pull encoder power on. Time begins to start anew after each teaching operation.

1. Set input on HIGH for 6 seconds. DV/ status output reflects the reverted input and will start oscillating after 5 seconds. Now set input on LOW.
2. Get cable-pull encoder in position 1 intended for voltage output 1/current 1.
3. Set input on HIGH for 1 second. DV/ status output will switch to LOW for 3 seconds and then start oscillating.
4. Get cable-pull encoder in position 2 intended for voltage output 2/current 2.
5. Set input on HIGH for 1 second. DV/Status output will switch to HIGH for 3 seconds and then shortly oscillate to signal that the teaching operation has been completed.

In the event of one out of both taught limits being beyond the sensing range or too close to each other, the DV/status output will oscillate shortly. There is no teaching of sensing range. The operation must be repeated under consideration of minimum teaching limit and sensing range.

Set / restore default

Set input on HIGH for 16 seconds. (After 5 seconds, the DV/status output will start oscillating while restoring default in second 15).

Note: The cable pull has to be completely drawn in.

Behavior

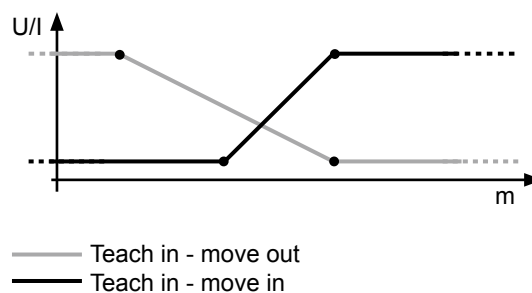

Absolute encoders - analog

Encoder with cable-pull

Magnetic sensing, resolution 12 bit

BMMS M50 / M75 analog / cable-pull - MAGRES

Terminal assignment

Cable

for connection reference -5

Core color	Analog signals		
	U/5	V	W
white	0 V	0 V	0 V
brown	+Vs	+Vs	+Vs
green	d.u.	lout	lout
yellow	Uout	d.u.	Uout
grey	Set	Set	Set
pink	DV/Status	DV/Status	DV/Status
Screen	connected to housing		
Cable data	6 x 0.14 mm ²		

Cable redundant

for connection reference -5

Core color	Analog signals	
	Y/7	Z
white	0 V	0 V
brown	+Vs 1	+Vs 1
green	Uout 1	lout 1
yellow	Uout 2	lout 2
grey	Set 1	Set 1
pink	DV/Status 1	DV/Status 1
blue	Set 2	Set 2
red	DV/Status 2	DV/Status 2
black	0 V	0 V
violet	+Vs 2	+Vs 2
Screen	connected to housing	
Cable data	10 x 0.14 mm ²	

Connector M12, 5-pin

for connection reference -N

Connector	Analog signals		
	U/5	V	W
Pin 1	0 V	0 V	0 V
Pin 2	+Vs	+Vs	+Vs
Pin 3	d.u.	lout	lout
Pin 4	Uout	d.u.	Uout
Pin 5	Set	Set	Set

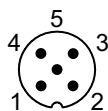

Connector M12, redundant, 2 x 5-pin

for connection reference -M

Connector	Connector 1	Connector 2
Pin 1	0 V	0 V
Pin 2	+Vs 1	+Vs 2
Pin 3	Uout 1 (Y/7) lout 1 (Z)	Uout 2 (Y/7) lout 2 (Z)
Pin 4	DV/Status 1	DV/Status 2
Pin 5	Set 1	Set 2

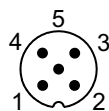

Absolute encoders - analog

Encoder with cable-pull

Magnetic sensing, resolution 12 bit

BMMS M50 / M75 analog / cable-pull - MAGRES

Dimensions

BMMS M50 cable radial

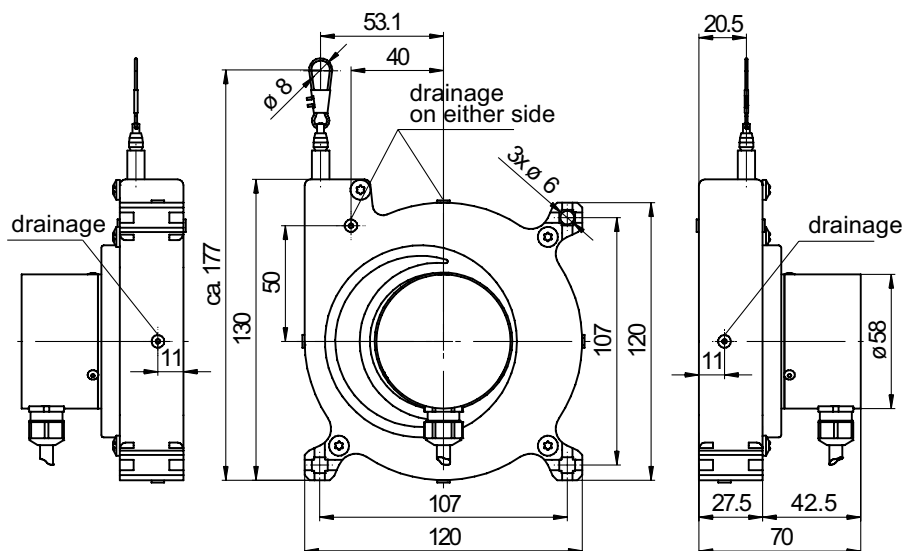

BMMS M50 connector M12

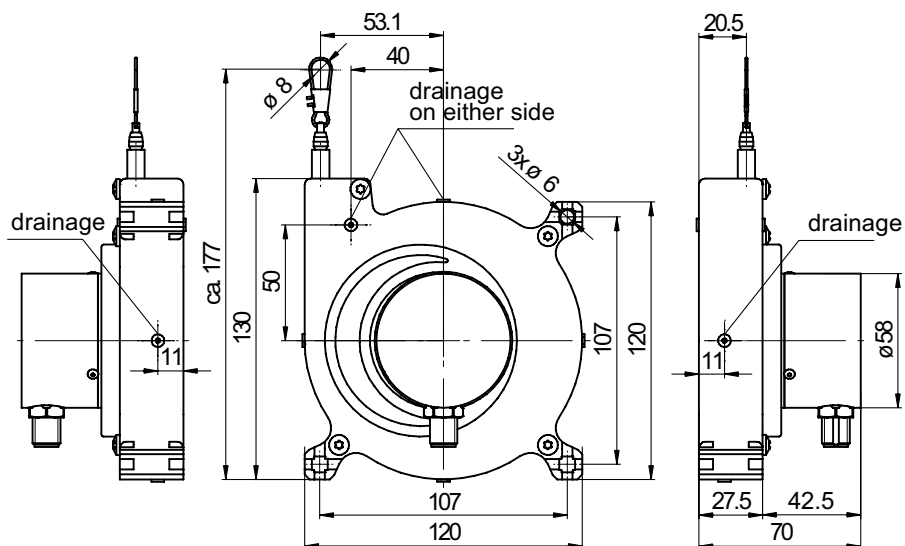

Absolute encoders - analog

Encoder with cable-pull

Magnetic sensing, resolution 12 bit

BMMS M50 / M75 analog / cable-pull - MAGRES

Dimensions

BMMS M50 connector 2 x M12

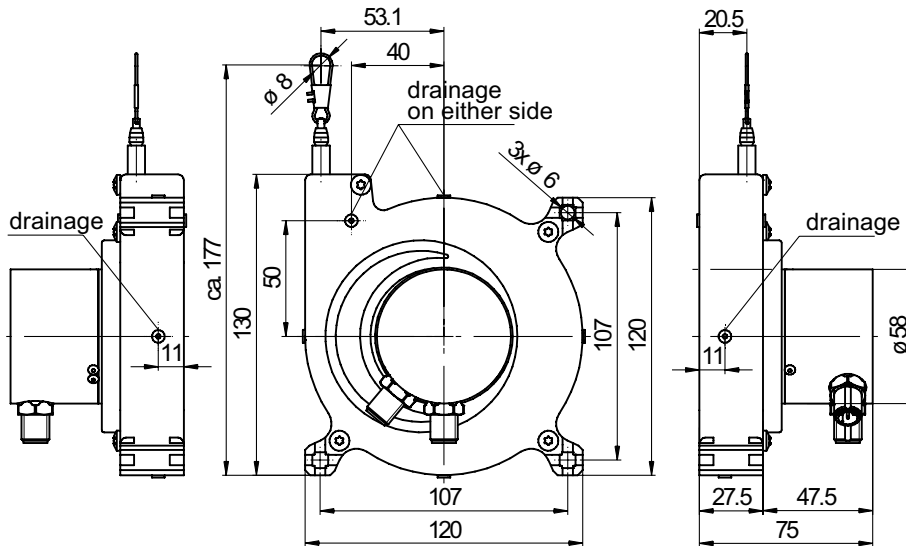

BMMS M75 cable radial

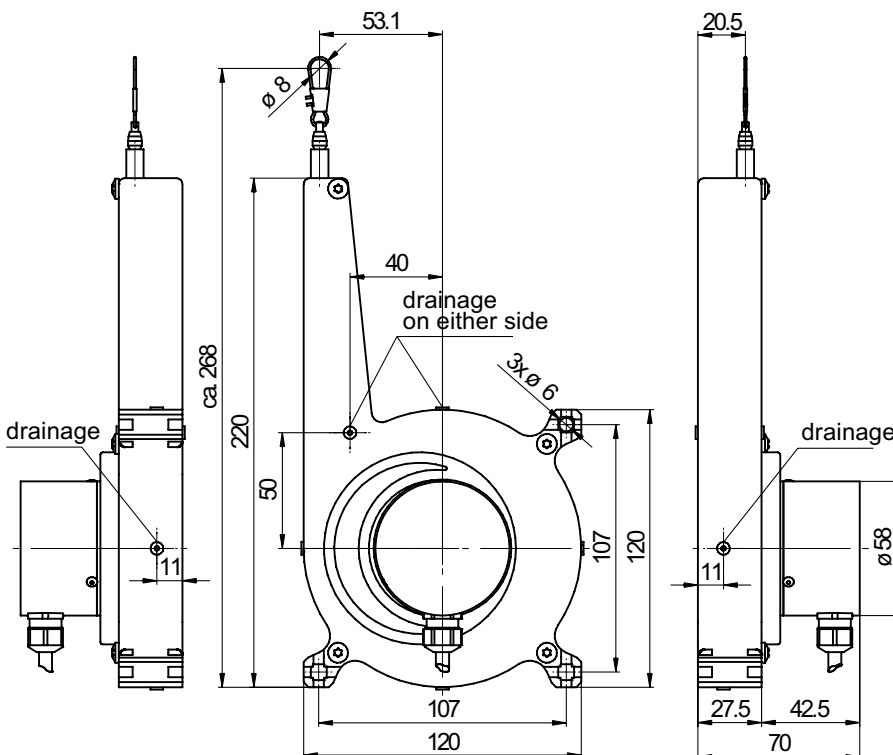

Absolute encoders - analog

Encoder with cable-pull

Magnetic sensing, resolution 12 bit

BMMS M50 / M75 analog / cable-pull - MAGRES

Dimensions

BMMS M75 connector M12

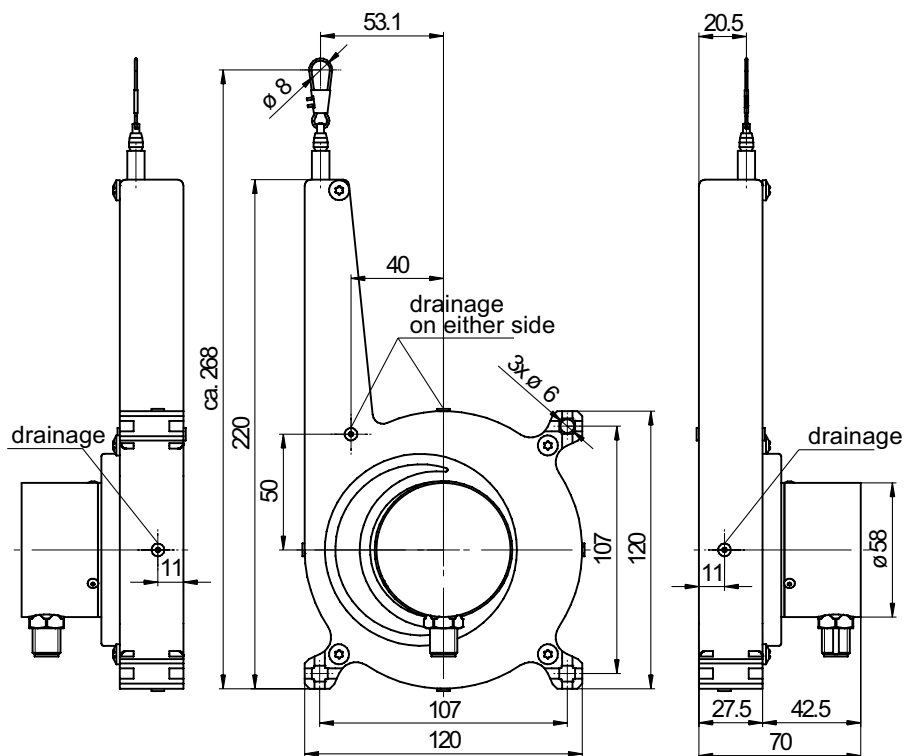

BMMS M75 connector 2 x M12

